

北京金煤创业科技股份有限公司
Beijing JinMei Entrepreneur Co., Ltd.

陶瓷复合破碎机配件
MMC-Crusher spare part

公司简介

Company profile

北京金煤创业科技股份有限公司于2006年成立，2016年改制为股份制公司并成功登陆新三板。公司总部坐落在中国北京中关村科技园古城基地。是集研发，生产，出口销售的互联网+新材料制造企业。

公司主营金属基陶瓷复合材料，耐磨耐热材料，冶金、矿山、水泥、燃煤热电厂设备配件等。产品：高铬陶瓷复合铸造耐磨材料，马氏体钢陶瓷复合铸造耐磨耐冲击材料及各类高锰钢陶瓷复合材料，金属基陶瓷纤维复合材料。

Beijing JinMei Entrepreneur Co., Ltd (DJM) was established in 2006, Headquarter located in Zhongguancun High-tech Park in Beijing, China. DJM was restructured into Joint-Stock company & listed on NEEQ in 2016. DJM's a research and development, production, export sales of Internet + new materials manufacturing enterprises.

DJM is focusing on Metal Matrix Ceramic Composite (MMCC) material, wear-resistant and heat-resistant material.

Products: High chromium cast iron ceramic composite castings, Martensite steel ceramic composite castings, high manganese steel ceramic composite castings, and Metal matrix ceramic fibre composite casting materials, ZTA ceramic mechanical parts. Products are widely used in metallurgical industry, mining, cement, Coal-fired thermal power plant as spare parts.



发明专利证书 Patent certificate

陶瓷高铬复合增强铸钢耐磨条板铸造工艺
Metal Matrix ceramic composite casting

陶瓷高锰钢复合耐磨件铸造工艺
High Mn Steel Matrix ceramic composite casting

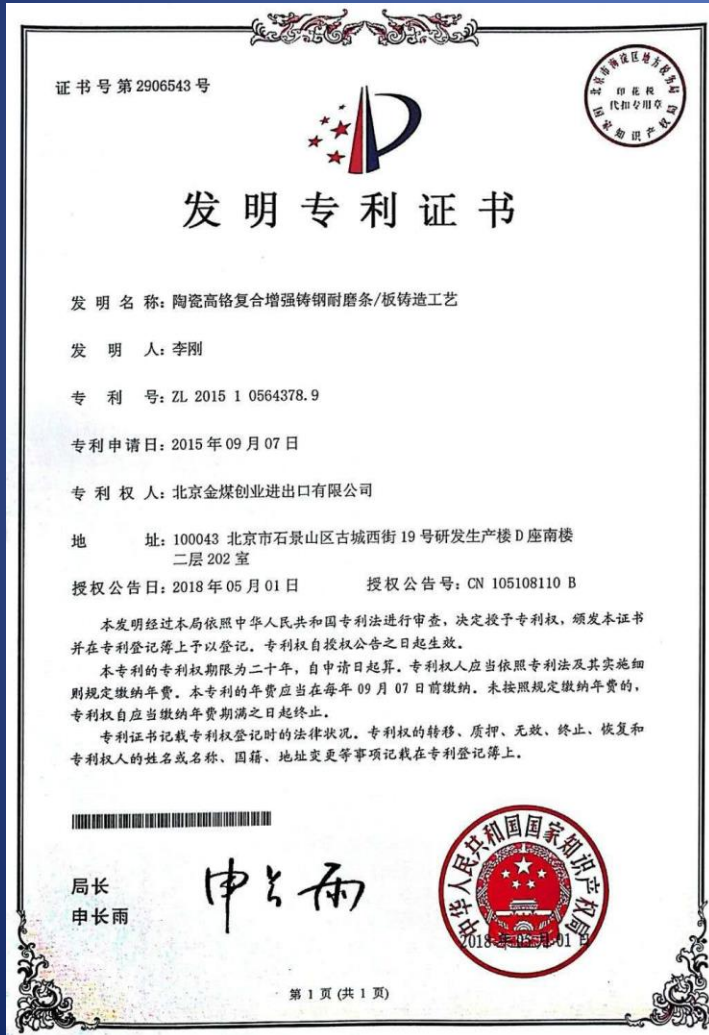

MMC-Cr 高铬铸铁陶瓷复合耐磨材料

MMC-Cr (High Chromium cast iron matrix ceramic insert casting wear-resistant material)

MMC-Cr (High Chromium cast iron matrix ceramic insert casting wear-resistant material)

That is, the reinforcement phase - ceramic particles are fused and cast in the easily worn parts of metal parts with high chromium cast iron as the base material. The metal-ceramic composite layer is formed by the metallurgical combination of ceramic particles and casting alloy. The metallurgical bonding of ceramic particles with metal is realized by the heat of metal liquid. The hardness of ceramic-ceramic composite layer formed by ceramic particles and matrix metal shows a step distribution. The hardness of ceramic particles in the composite layer can reach 3-4 times of the hardness of high chromium cast iron material, so as to achieve the anti-wear effect; Compared with ordinary high chromium cast iron, the service life of the product is greatly extended.

The hardness of the High chromium iron ceramic composite layer is distributed in steps:

Ceramic particles hardness= HV2100

Hardness of metal around ceramic particles = 60-65HRC

Hardness of Basis material =High chromium iron = 58-62HRC

Suitable for use under low impact and high wear conditions

MMC-Cr 高铬铸铁陶瓷复合耐磨材料

即在高铬铸铁为基材的金属部件易磨损部位熔铸增强相-陶瓷颗粒.通过陶瓷颗粒与铸造合金的冶金结合来实现金属陶瓷复合并形成金属陶瓷复合层;陶瓷颗粒与金属的冶金结合是通过金属液体的热量来实现的;陶瓷颗粒与基体金属形成金属陶瓷复合层的硬度呈阶梯分布:复合层中陶瓷颗粒的硬度可达高铬铸铁材料硬度的3-4倍,从而实现抗磨的效果;与普通高铬铸铁件相比,产品使用寿命大幅度延长。

高铬陶瓷复合层的硬度呈阶梯分布:

陶瓷颗粒硬度= HV2100

陶瓷颗粒周围的金属硬度= 60-65HRC

基材硬度=高铬铸铁= 58-62HRC

适合在低冲击和高磨损条件下使用

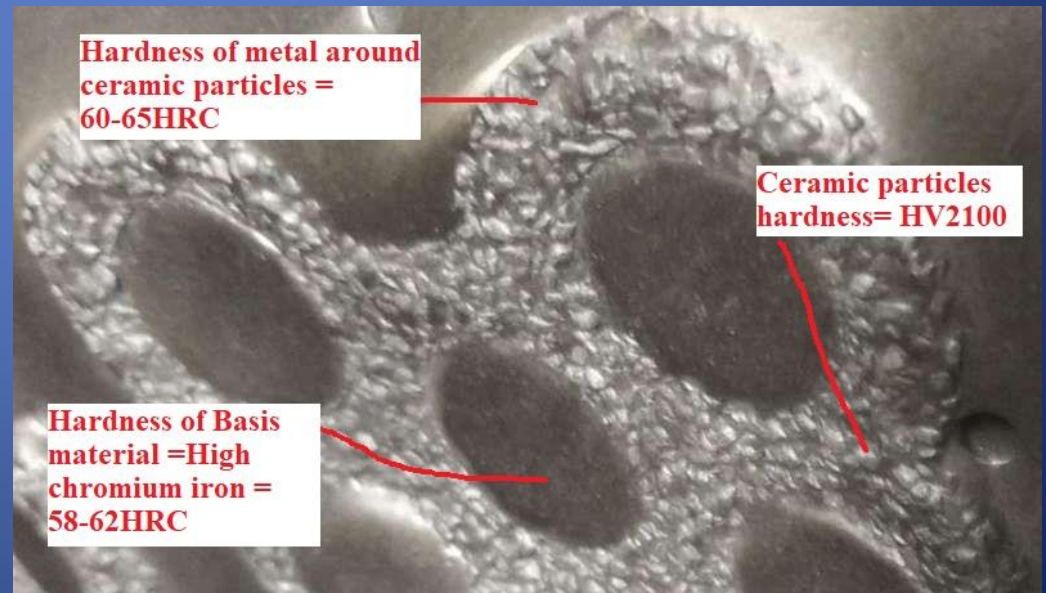

MMC-M 马氏体钢陶瓷复合耐磨材料

MMC-M (Martensite steel matrix ceramic Insert casting Wearparts)

MMC-M (Martensite steel matrix ceramic insert casting wear-resistant material)

That is, the reinforcement phase - ceramic particles are cast in the easily worn parts of the metal parts with martensitic steel as the base material. The metal-ceramic composite layer is formed by the metallurgical combination of ceramic particles and casting alloy. The metallurgical bonding of ceramic particles with metal is realized by the heat of metal liquid. The hardness of ceramic-ceramic composite layer formed by ceramic particles and matrix metal is distributed in a step: give full play to the characteristics of high strength and high hardness of martensitic steel, reduce the plastic deformation of metal parts, and improve the impact resistance; Combined with the high wear resistance of ceramic particles, the anti-wear performance of the working surface is improved. The result is a metal component that is both wear resistant and impact resistant. Due to the selection of martensitic steel as the base material, so that the composite material has a good welding, and processing properties, while the product is suitable for flame gas cutting, grinding wheel saw, shear, water cutting, plasma and other cutting methods, welding without preheating or subsequent heating treatment; Compared with ordinary high chromium cast iron, the service life of the product is greatly improved.

The hardness of the Martensite Steel ceramic insert composite layer is distributed in steps:

Ceramic particles hardness= HV2100

Hardness of metal around ceramic particles = 60-65HRC

Hardness of Basis material =Martensite Steel = 48-53HRC

It is suitable for use under high impact and high wear conditions and can be welded

MMC-M 马氏体钢陶瓷复合耐磨材料

即在马氏体钢为基材的金属部件易磨损部位熔铸增强相-陶瓷颗粒.通过陶瓷颗粒与铸造合金的冶金结合来实现金属陶瓷复合并形成金属陶瓷复合层;陶瓷颗粒与金属的冶金结合是通过金属液体的热量来实现的;陶瓷颗粒与基体金属形成金属陶瓷复合层的硬度呈阶梯分布:充分发挥马氏体钢的高强度及高硬度特点,减少金属部件的塑性变形,提高抗冲击能力;结合陶瓷颗粒的高耐磨特性,提高工作面的抗磨性能;从而获得即耐磨且抗冲击的金属部件。因选用马氏体钢为基材,从而使复合材料具有很好的焊接,及加工性能,同时产品适用火焰气割,砂轮锯,剪切,水割,等离子等多种切割方式切割,焊接时无需对其进行预热或后续加热处理;与普通高铬铸铁件相比,产品使用寿命大幅度提高。

马氏体钢陶瓷复合层的硬度分布:

陶瓷颗粒硬度= HV2100

陶瓷颗粒周围的金属硬度= 60-65HRC

基体硬度=马氏体钢硬度= 48-53HRC

适合在高冲击、高磨损条件下使用,可焊接



MMC-Mn高锰钢陶瓷复合耐磨材料

MMC-Mn (High Manganese Steel Ceramic Insert casting wearparts)

MMC-Mn (High-manganese ceramic insert casting wear-resistant material)

That is, the reinforcement phase - ceramic particles are fused and cast in the easily worn parts of metal parts with high manganese steel as the base material. The metal-ceramic composite layer is formed by the metallurgical combination of ceramic particles and casting alloy. The metallurgical bonding of ceramic particles with metal is realized by the heat of metal liquid. The hardness of ceramic-ceramic composite layer formed by ceramic particles and matrix metal shows a step distribution. In the casting engineering, alloy elements in composite ceramic materials are used to refine the grain of high-manganese steel, improve the matrix properties of high-manganese steel, give full play to the work-hardening characteristics of high-manganese steel, reduce plastic deformation, and improve the low-impact wear resistance. Combined with the high wear resistance of the ceramic material, the wear resistance of the working surface is improved, so that the wear-resistant and impact-resistant material is obtained. The life of high manganese steel ceramic composite is greatly improved.

The hardness of the High manganese steel ceramic insert composite layer is distributed in steps:

Ceramic particles hardness= HV2100

Hardness of metal around ceramic particles = 60-65HRC

Basis material=High manganese steel =Hardness HB190-220

Impact hardness of High manganese steel = HB400-500

It is suitable for use under high impact and high wear conditions

MMC-Mn 高锰钢陶瓷复合耐磨材料

即在高锰钢为基材的金属部件易磨损部位熔铸增强相-陶瓷颗粒.通过陶瓷颗粒与铸造合金的冶金结合来实现金属陶瓷复合并形成金属陶瓷复合层;陶瓷颗粒与金属的冶金结合是通过金属液体的热量来实现的;陶瓷颗粒与基体金属形成金属陶瓷复合层的硬度呈阶梯分布:在浇铸工程中利用复合陶瓷材料中的合金元素细化高锰钢晶粒,提高高锰钢基体性能,充分发挥高锰钢的加工硬化特点,减少塑性变形,提高低冲击耐磨能力;结合陶瓷材料的高耐磨特性,提高工作面的抗磨性能,从而获得即耐磨且抗冲击的耐磨材料。高锰钢陶瓷复合材料的寿命大幅度提高。

高锰钢陶瓷复合层的硬度呈阶梯分布:

陶瓷颗粒硬度= HV2100

陶瓷颗粒周围的金属硬度= 60-65HRC

基材=高锰钢=硬度HB190-220

高锰钢冲击硬度= HB400-500

适合在高冲击、高磨损条件下使用

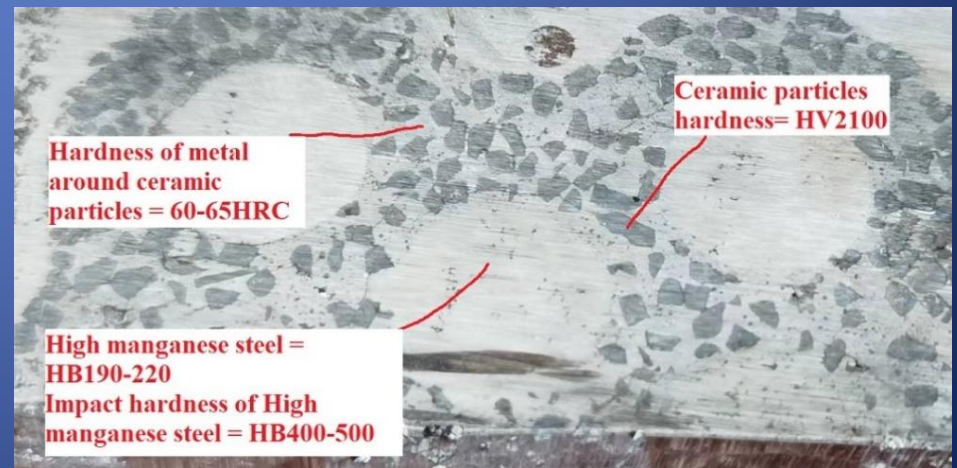

专利技术证书 (齿板)

Patent certificate (Jaw plate)

证书号第 4204573 号



实用新型专利证书

实用新型名称: 蜂窝 ZTA 陶瓷复合高锰钢齿板结构

发 明 人: 李刚

专 利 号: ZL 2014 2 0557071.7

专利申请日: 2014 年 09 月 25 日

专 利 权 人: 北京金煤创业进出口有限公司

授权公告日: 2015 年 03 月 25 日

本实用新型经过本局依照中华人民共和国专利法进行初步审查, 决定授予专利权, 颁发本证书并在专利登记簿上予以登记。专利权自授权公告之日起生效。

本专利的专利权期限为十年, 自申请日起算。专利权人应当依照专利法及其实施细则规定缴纳年费。本专利的年费应当在每年 09 月 25 日前缴纳。未按照规定缴纳年费的, 专利权自应当缴纳年费期满之日起终止。

专利书记载专利权登记时的法律状况, 专利权的转移、质押、无效、终止、恢复和专利权人的姓名或名称、国籍、地址变更等事项记载在专利登记簿上。



局长
申长雨



2015 年 03 月 25 日

第 1 页 (共 1 页)

(19) 中华人民共和国国家知识产权局



(12) 实用新型专利



(10) 授权公告号 CN 204220193 U
(45) 授权公告日 2015.03.25

(21) 申请号 201420557071.7
(22) 申请日 2014.09.25
(73) 专利权人 北京金煤创业进出口有限公司
地址 100043 北京市石景山区古城西街 19 号研发生产楼 D 座南楼二层 202 室
(72) 发明人 李刚
(74) 专利代理机构 北京方圆嘉禾知识产权代理有限公司 11385
代理人 董芙蓉

(51) Int. Cl.
B02C 1/04(2006.01)
B02C 1/10(2006.01)

权利要求书1页 说明书2页 附图5页

(54) 实用新型名称
蜂窝 ZTA 陶瓷复合高锰钢齿板结构

(57) 摘要
本实用新型涉及一种蜂窝 ZTA 陶瓷复合高锰钢齿板结构, 包括齿板本体, 齿板本体上设置数个平行设置的齿部, 相邻齿部之间的底部和/或齿部的磨削面上镶嵌数块陶瓷层, 镶嵌 ZTA 陶瓷的高锰钢齿板实现了高锰钢与陶瓷的完美结合, 使高锰钢齿板的耐磨性能大大提高, 既提高了高锰钢齿板的耐磨强度, 又增加了高锰钢齿板的使用时间, 减少了更换高锰钢齿板的次数, 提高了生产效率, 节约了生产成本。



CN 204220193 U

高锰钢陶瓷复合鄂碎齿板

High Mn Steel Matrix ceramic composite jaw plate



2018-10-22



2018-10-22

高锰钢陶瓷复合鄂碎齿板

High Mn Steel Matrix ceramic composite jaw plate

DJM chooses high manganese steel as base material of the ceramic composite materials, which is plate basement with high manganese steel and then embed the high wear resistance With stiffener into the basement. Below keeping original work hardening of high manganese steel impact resistance performance and improving wear resistance strength at the same time.

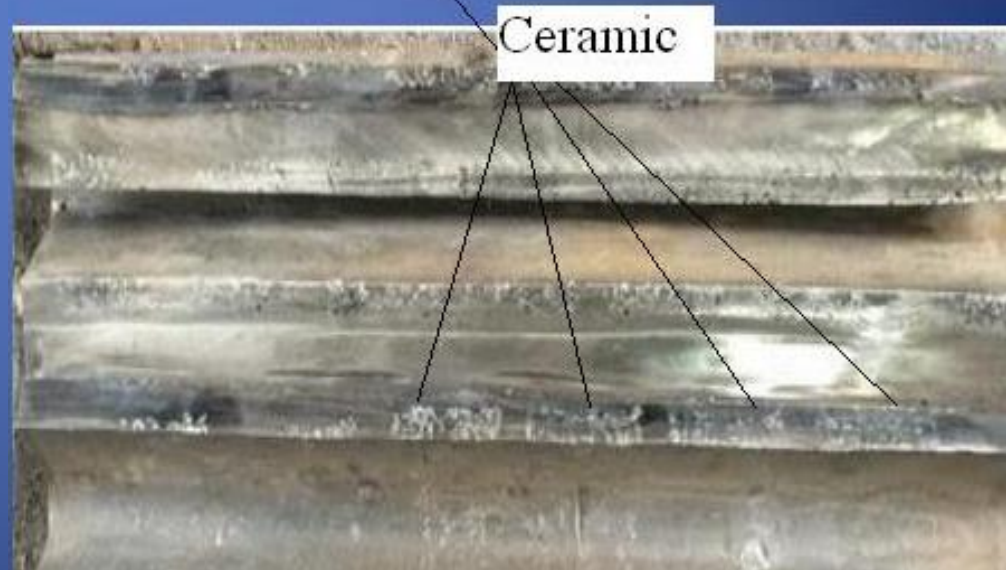
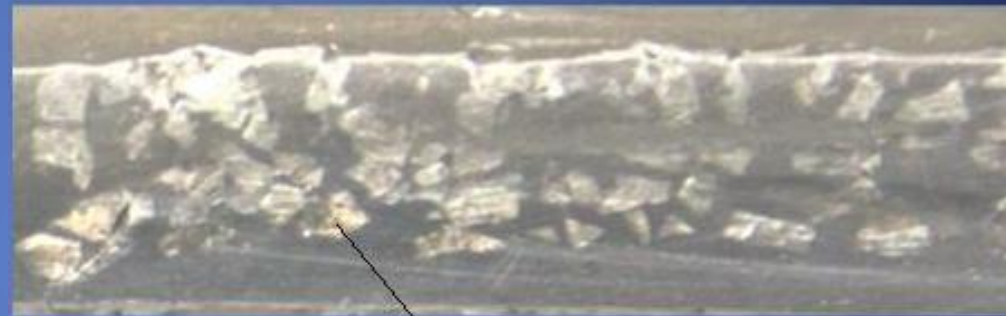

高锰钢陶瓷复合鄂碎齿板-使用25天后

High Mn Steel Matrix ceramic composite jaw plate-use after 25days



高锰钢陶瓷复合破碎壁/扎臼壁

High Mn Steel Matrix ceramic composite Cone/Mantle

DJM adopts composites of high-manganese steel substrate and ceramic, namely, the base material of the cone and mantle is high Mn steel, while the cast ceramic matrix embedded with high wear resistance shaped ribs, increase the wear resistance ability while maintaining the original impact resistance of high manganese steel.

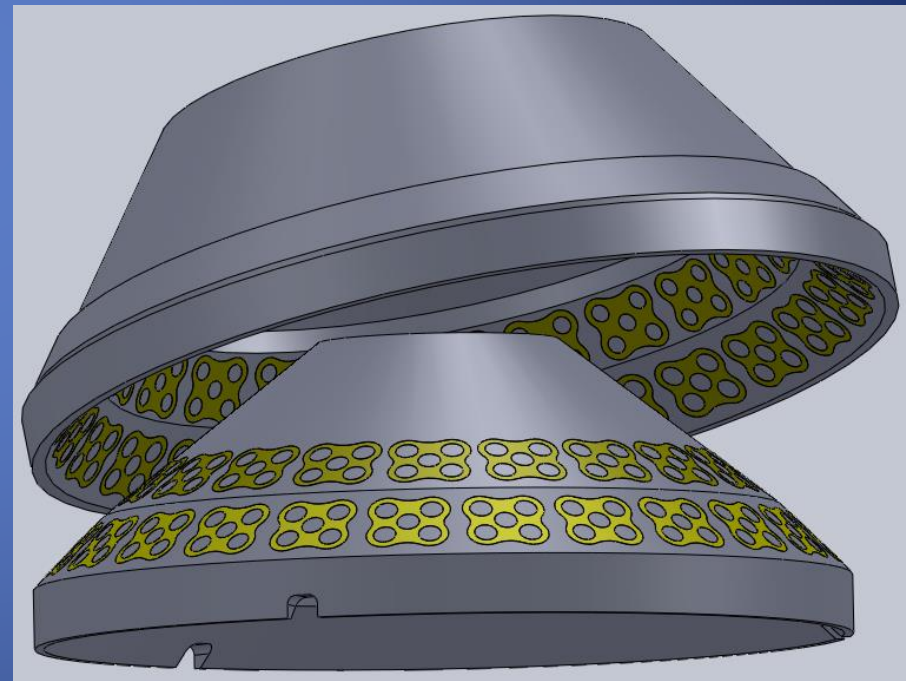
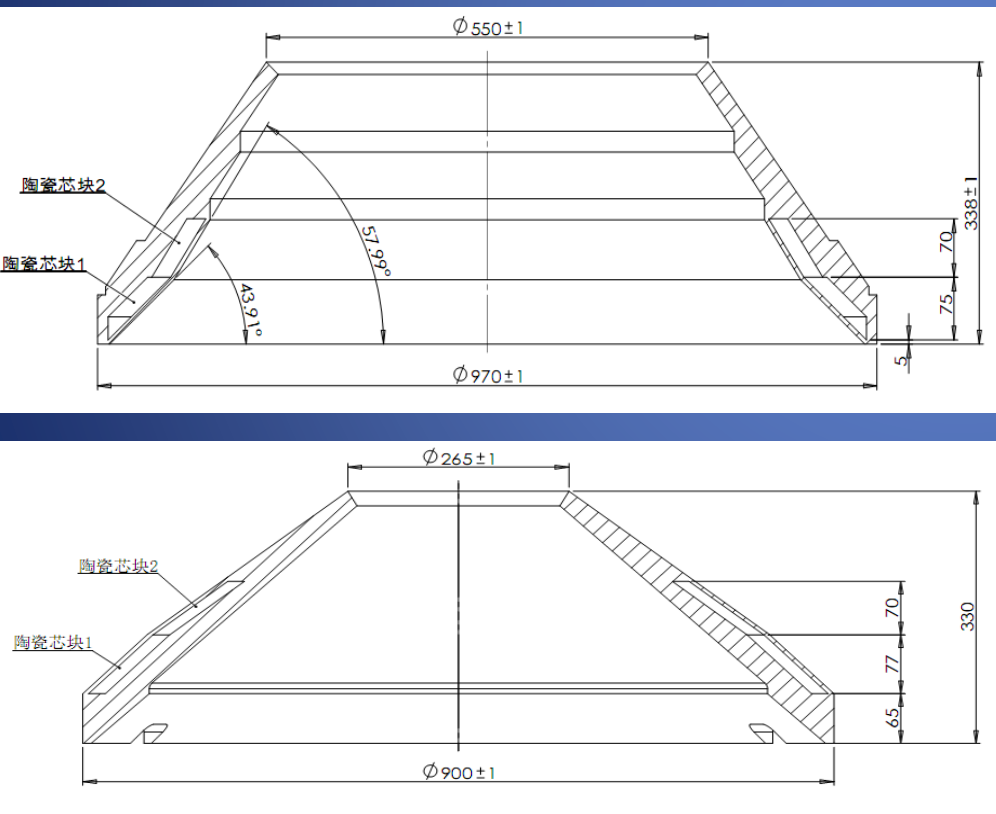

高锰钢陶瓷复合破碎壁/扎臼壁 High Mn Steel Matrix ceramic composite Cone/Mantle



高锰钢陶瓷复合破碎壁/扎白壁

High Mn Steel Matrix ceramic composite Cone/Mantle



高锰钢陶瓷复合破碎壁/扎白壁-使用实例

High Mn Steel Matrix ceramic composite Cone/Mantle

圆锥破碎机GP300（二破）扎白壁/破碎壁使用实例

物料- 铁矿石-莫氏硬度6.5 进料粒度= 50-300mm

磨损形式=高冲击碾压磨损

高锰钢扎白壁 使用寿命=22天 (440hour)



高锰钢陶瓷复合扎白壁 使用寿命=45天 (900hour)



专利技术证书 (板锤)

Patent certificate (Blow bar)

证书号第 4236528 号

实用新型专利证书

实用新型名称: 蜂窝 ZTA 陶瓷复合高铬铸铁板锤结构

发明人: 李刚

专利号: ZL 2014 2 0557072.1

专利申请日: 2014 年 09 月 25 日

专利权人: 北京金煤创业进出口有限公司

授权公告日: 2015 年 04 月 15 日

本实用新型经过本局依照中华人民共和国专利法进行初步审查, 决定授予专利权, 颁发本证书并在专利登记簿上予以登记。专利权自授权公告之日起生效。

本专利的专利权期限为十年, 自申请日起算。专利权人应当依照专利法及其实施细则规定缴纳年费。本专利的年费应当在每年 09 月 25 日前缴纳。未按照规定缴纳年费的, 专利权自应当缴纳年费期满之日起终止。

专利书记载专利权登记时的法律状况。专利权的转移、质押、无效、终止、恢复和专利权人的姓名或名称、国籍、地址变更等事项记载在专利登记簿上。



局长
申长雨



2015 年 04 月 15 日

第 1 页 (共 1 页)

(19) 中华人民共和国国家知识产权局



(12) 实用新型专利



(10) 授权公告号 CN 204261737 U
(45) 授权公告日 2015.04.15

(21) 申请号 201420557072.1
(22) 申请日 2014.09.25
(73) 专利权人 北京金煤创业进出口有限公司
地址 100043 北京市石景山区古城西街 19 号研发生产楼 D 座南楼二层 202 室
(72) 发明人 李刚
(74) 专利代理机构 北京方圆嘉禾知识产权代理有限公司 11385
代理人 董芙蓉
(51) Int. Cl.
B02C 13/28(2006.01)

权利要求书1页 说明书2页 附图2页

(54) 实用新型名称
蜂窝 ZTA 陶瓷复合高铬铸铁板锤结构

(57) 摘要
本实用新型涉及一种蜂窝 ZTA 陶瓷复合高铬铸铁板锤结构, 包括板锤本体, 在板锤本体的工作面上镶嵌有数块陶瓷层, 所述陶瓷层为陶瓷芯块, 其中所述陶瓷芯块大体呈一长方体结构, 陶瓷芯块的端面上设置一个或多个透孔, 同时陶瓷芯块的边缘端面上设置数个凹槽, 透孔与凹槽轴向平行, 透孔和凹槽内分别填制粘结在一块的陶瓷粉末, 本实用新型使高铬铸铁板锤的耐磨性能大大提高, 既提高了高铬铸铁板锤的耐磨强度, 又增加了高铬铸铁板锤的使用时间, 减少了更换高铬铸铁板锤的次数, 提高了生产效率, 节约了生产成本。

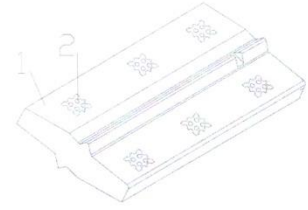

CN 204261737 U

反击破板锤 Blow Bars

- DJM chooses high-chrome cast iron (or martensitic steel) ceramic composite material to make the blow bar: in the high chromium cast iron (or martensitic steel) material embedded ceramic particles on the surface to form ceramic metal composite material layer, the wear resistance of the composite layer can be up to 3 to 4 times higher than the high Cr material, and the thickness of the composite layer can be made 1/3 of the thickness of the original part. Compared with common High Cr, the product life has been greatly improved.

附图-1-1 高 Cr 陶瓷复合板锤外观图

Picture 1-1 external view



附图-1-2 高 Cr 陶瓷复合板锤外观局部放大图

Picture 1-2 partial enlargement of appearance



陶瓷金属复合破碎机板锤

Metal ceramic composite Blow bar

DJM能提供各种板锤的设计和合金材质方案，材质从标准合金铸钢到马氏体钢，以及金属陶瓷复合材料等。

- 行业：破碎/回收
- 设备：水平冲击式破碎机、立轴冲击破碎机
- 原理：冲击破碎
- 技术要点：
 - 金属陶瓷复合高锰钢（高冲击条件下：初级破碎--混凝土回收）
 - 金属陶瓷复合马氏体钢（高冲击高冲剉刨削条件下：初级破碎--混凝土回收）
 - 金属陶瓷复合中铬铸铁（中级冲击条件下：二级、三级—软土和沥青回收利用）
 - 金属陶瓷复合高铬铸铁（低中级冲击条件下：二级、三级—预压碎混凝土）
- 主要优点：提高使用寿命，是本体材料的2—3倍

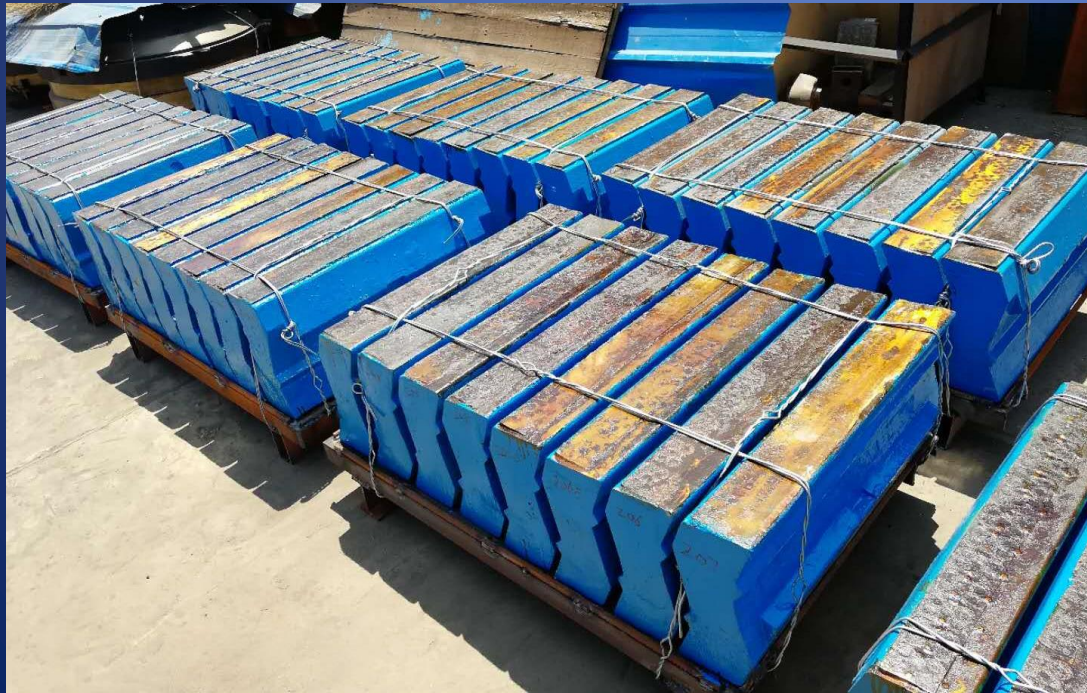

反击破板锤 Blow Bars

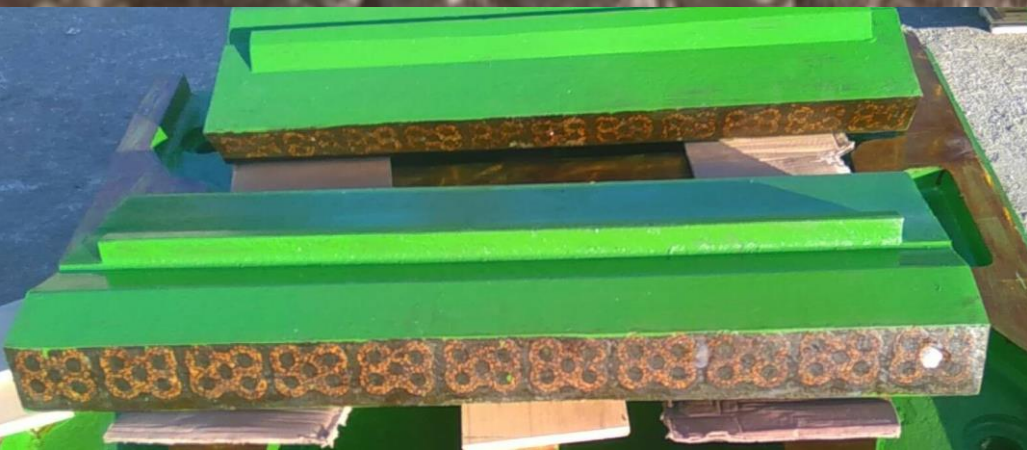

反击破板锤 Blow Bars



使用实例 -(反击破板锤) the use of examples-(blow bar)

- 物料=建筑垃圾混凝土 莫氏硬度=4-5 进料粒度= 0-400mm
- 磨损形式=冲击凿削磨料磨损 (Impact gouging abrasion)
- 使用者及设备= Keestrack公司反击破板锤
- 马氏体钢铸造反击破板锤(F60)=120-130小时
- DJM 马氏体钢+陶瓷复合铸造反击破板锤
-(F60+ZTA)=200-250小时
- 高铬铸造反击破板锤(2021) =180-200小时
- DJM 高铬+陶瓷复合铸造反击破板锤
-(2021+ ZTA) =350-400小时



立轴破(制砂机)蹄锤/抛头/粉料锥 Anvil/Shoe hammer /Impeller of VSI Crusher

In order to get a further improvement of the wear life, DJM selects high-Cr cast iron(or martensite steel)ceramic composite materials, which forms the ceramic metal composite reinforcement through injection of ceramic particles into the high-Cr material , the composite layer wear-resisting property is than high Cr material 3-4 times, at the same time, the composite layer thickness can be made to a third of the thickness of the original spare parts. Ceramic composite material blow bar life has been greatly improved.

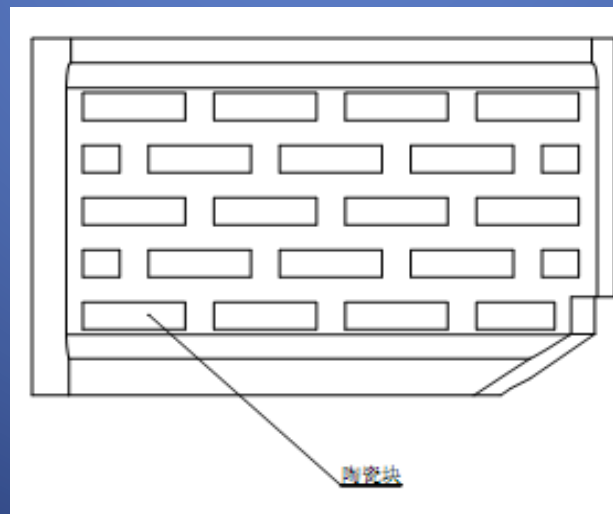
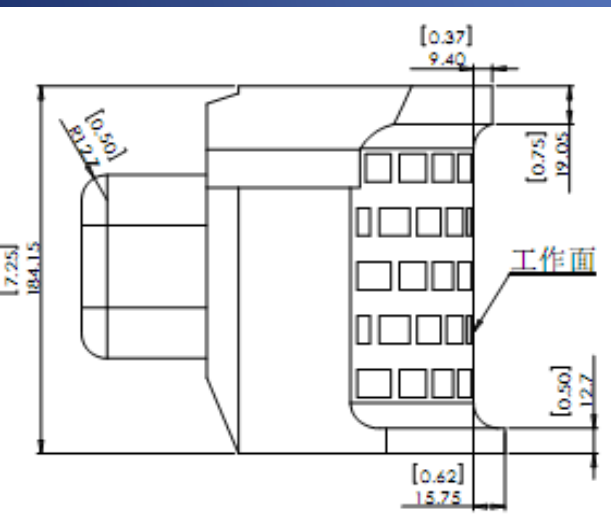

立轴破(制砂机)蹄锤/抛头 Anvil/Shoe hammer of VSI Crusher

附图-2 高 Cr 陶瓷复合蹄形锤头外观图

Picture -2 external view



附图-3 高 Cr 陶瓷复合蹄形锤头外观局部放大图

Picture -3 partial enlargement of appearance



附图-1-4 高 Cr 陶瓷复合蹄形锤头局部解剖图

Picture 1-4 Part sectioned view

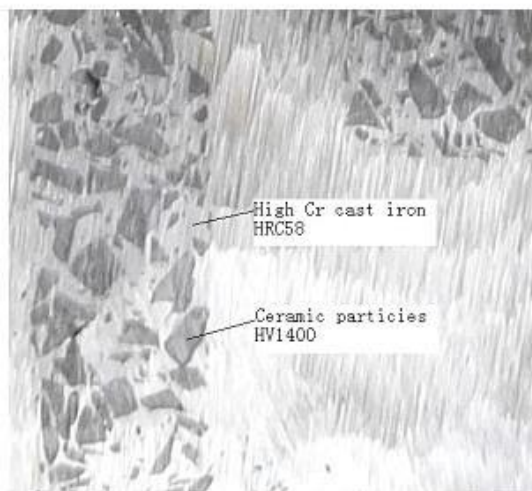

立轴破(制砂机)蹄锤/抛头 Anvil/Shoe hammer of VSI Crusher

- DJM的蹄锤/抛头可以有多种设计方案和合金材质：可以是合金或金属陶瓷复合材质，以满足不同的生产条件。
- 行业：破碎/回收
- 设备：立轴式冲击破碎机
- 原理：冲击破碎
- 技术要点：
 - 可以有多种的设计方案（选择最优的方案，以优化工艺和耐磨性能）
 - 高耐磨陶瓷镶嵌在耐冲击金属基体中。
 - 材质：合金或金属陶瓷复合才能以适应不同的工况条件。
 - 优点：增加使用寿命，可达原本体材料的2--3倍



立轴破(制砂机)蹄锤/抛头/粉料锥
Anvil/Shoe hammer /Impeller of VSI Crusher



立轴反击破使用实例

Practical application case of Impact Crusher

- 物料--金矿尾矿- (钾长石 莫氏硬度=6) --进料粒度= 0-100mm
- 磨损形式=冲击凿削磨料磨损 (Impact gouging abrasion)
-
- 高锰钢 (Mn13) 反击板使用寿命= 72小时 使用72小时后每小时磨耗=0.36kg
- 马氏体钢 (ZG40Cr3Si2Mn2MoV) 反击板使用寿命= 100-120小时 使用100小时后每小时磨耗=0.26kg
- 高锰钢 (Mn18Cr2+RE) 反击板使用寿命= 120-150小时 使用120小时后每小时磨耗=0.216kg
- MMC-Mn (Mn18Cr2+Mn ZTA) 使用寿命= 200-250小时 使用200小时后每小时磨耗=0.0925kg
- MMC-Cr (GX260Cr18NiMo + ZTA) 使用寿命= 250-300小时 使用200小时后每小时磨耗=0.085kg
- MMC-Cr (Cr25Cu + ZTA) 使用寿命= 300-350小时 使用200小时后每小时磨耗=0.057kg

使用 200 小时后, 原始重量=44kg 残余重=25.5kg after 200 hour, residue weight=25.5kg 每小时磨耗=0.0925kg



金属陶瓷复合铸造锤头

Metal matrix ceramic composite Hammer

- DJM选用高锰钢为基体熔铸陶瓷颗粒的复合铸造工艺制作锤头，采用粉末冶金制芯结合铸造烧结工艺，在浇铸过程中利用复合陶瓷材料降低钢水温度，利用复合陶瓷材料中的合金元素细化高锰钢晶粒，提高基体性能，充分发挥高锰钢的高强度且耐冲击的特点，提高锤头的抗冲击能力；结合复合陶瓷材料的高耐磨特性，提高锤头工作面的抗磨性能，从而获得即耐磨且抗冲击的锤头。大幅提高使用寿命。
- 行业：破碎
- 设备：锤式冲击破碎机
- 原理：凿削破碎
- 技术要点：
 - 金属陶瓷复合高锰钢（高冲击条件下的凿削破碎）
 - 金属陶瓷复合马氏体钢（高冲击高冲涮刨削条件下的凿削破碎）
 - 金属陶瓷复合中铬铸铁（低中级冲击条件下的凿削破碎）
- 优点：增加使用寿命，可达原本体材料的1—3倍



金属陶瓷复合铸造锤头

Metal matrix ceramic composite Hammer



陶瓷双金属复合铸造锤头
Bimetal matrix ceramic composite Hammer



金属陶瓷复合铸造可焊接耐磨条/板专利技术介绍

Patent of Metal Matrix ceramic composite casting

(entire surface ceramic and weldability wear-resistant plate)

- Weldable wear-resistant bar/liner is martensitic steel and ZTA ceramic composite casting and looks like chocolate. the composite layer wear-resisting property is 2-3 times more than Alloy steel material, and the thickness can be only 1/3 of the before spare part. The mild steel backing plate has very good welding performance while bearing high impact. This product is very easy to use. It's easy to be cut and welded on curved surface without pre-heat or post heat treatment. It's easy to be transported as it's very small. It's an ideal production to repair the small wearing and tearing area without too much welding time. We have complete range of specification and are able to customize and develop according to customer's requirement. Comparing with normal High Cr wear resistant casting wear parts, the product life has been greatly improved

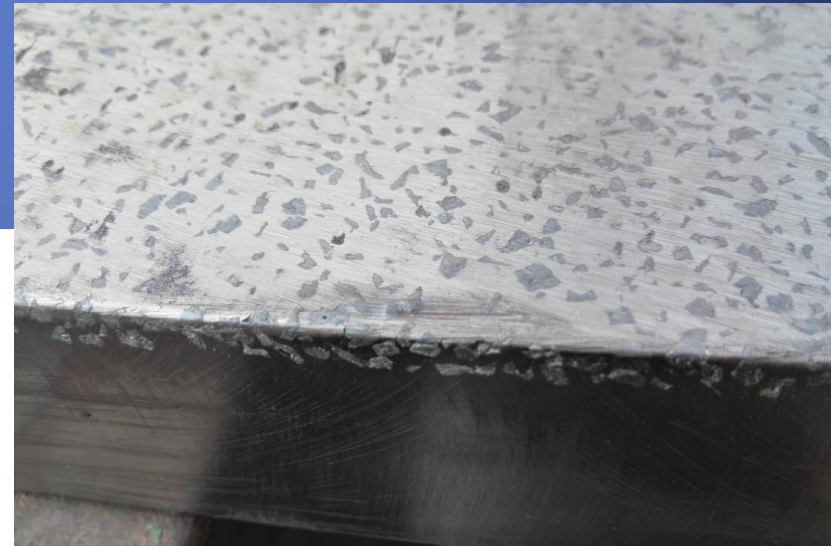
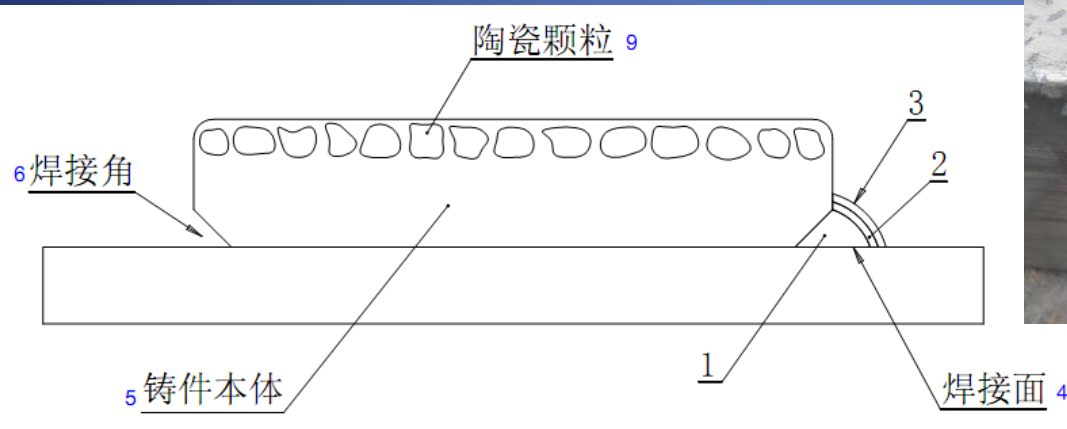

金属陶瓷复合铸造可焊接耐磨条/板(修补焊接用)
Martensite steel ceramic composite wear parts
(weldability wear-resistant bar/liner)



●
谢谢！ / Thanks！

Beijing JinMei Entrepreneur Co., Ltd (DJM)

Tel: 86-10-8890 9291

Mp: 86-13901376361

WhatsApp: +86-13901376361

Email: info@djm-bj.com leegang@djm-bj.com

Web: www.djm-bj.com <https://m.djm-bj.com/m/>

北京金煤创业科技股份有限公司

北京市石景山区古盛路36号院1号楼14层1403室 邮编: 100043

Room No.1403 TaiRan Building, No.36 GuSheng Road, ShiJingShan District, Beijing, China.100043